

# HSF

NOTES:  
 Rated Current:2.9A  
 Contact Resistance:15mΩ Max.  
 Applicable Wire:0.3sq.,AWG#28,#30  
 Operating Temperature Range:  
 Components: -55°C to +125°C  
 Cable Assembly with PVC Cable: -10°C to +80°C  
 Cable Assembly with Teflon Cable: -40°C to +125°C

Table 1:

PIN No.	PART No.	DIM. A	DIM. B
2*2	3601-2HX02B01	2.92	1.27
2*3	3601-2HX03B01	4.19	2.54
2*4	3601-2HX04B01	5.46	3.81
2*5	3601-2HX05B01	6.73	5.08
2*6	3601-2HX06B01	8.00	6.35
2*7	3601-2HX07B01	9.27	7.62
2*8	3601-2HX08B01	10.54	8.89
2*10	3601-2HX10B01	13.08	11.43
2*15	3601-2HX15B01	19.43	17.78
2*20	3601-2HX20B01	25.78	24.13
2*25	3601-2HX25B01	32.13	30.48
2*30	3601-2HX30B01	38.48	36.83
2*35	3601-2HX35B01	44.83	43.18
2*40	3601-2HX40B01	51.18	49.53
2*45	3601-2HX45B01	57.53	55.88
2*50	3601-2HX50B01	63.88	62.23

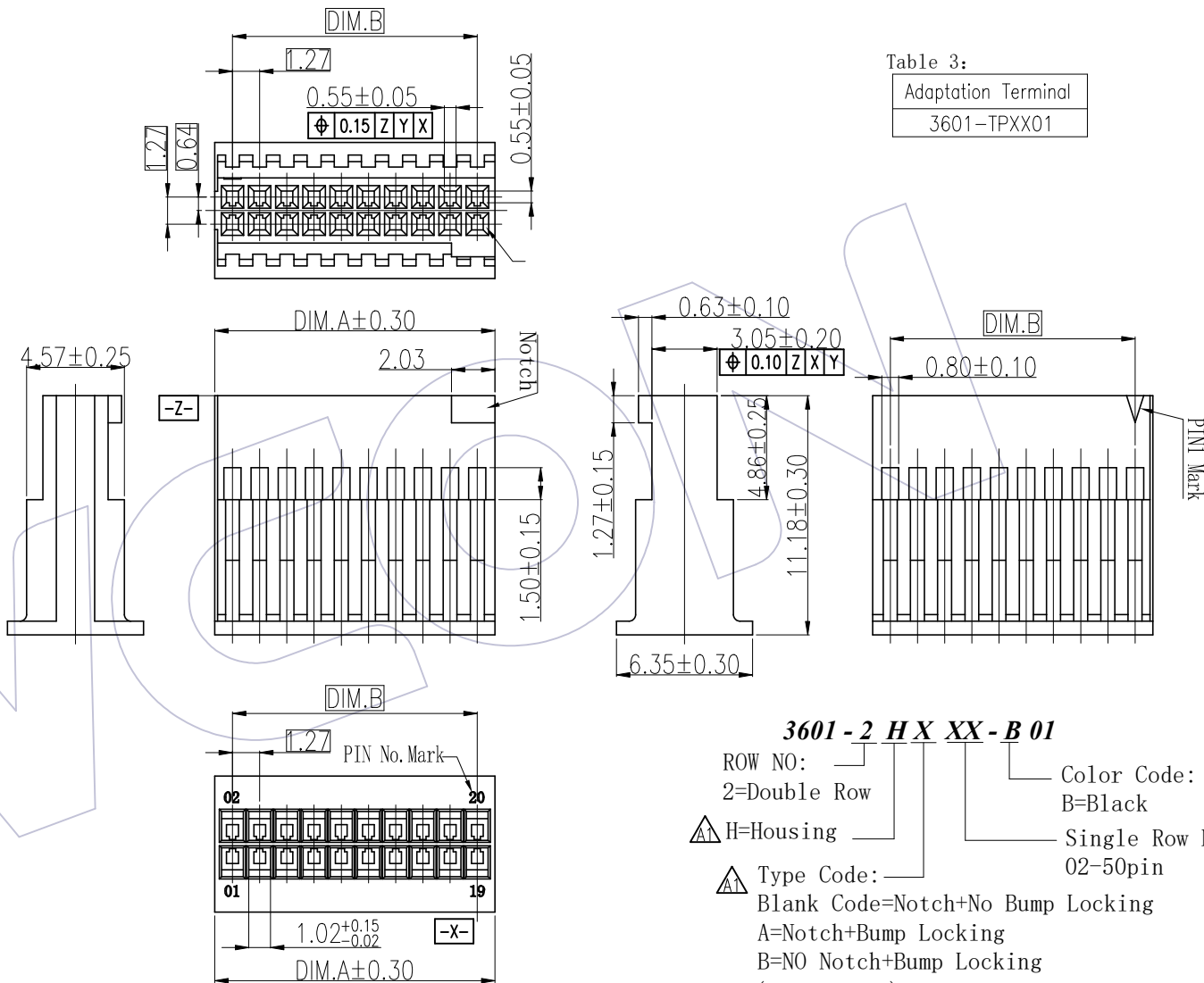

Table 3:

Adaptation Terminal
3601-TPXX01

**3601-2HXXX-B01**

ROW NO: [ ] Color Code: [ ]  
 2=Double Row B=Black  
 H=Housing Single Row No. : [ ]  
 Type Code: [ ] 02-50pin  
 Blank Code=Notch+No Bump Locking  
 A=Notch+Bump Locking  
 B=NO Notch+Bump Locking  
 (See Table2)

REV	DATE	MODIFICATION DESCRIPTION	CHANGE	OPERATION		DRAW	DATE	SCALE	FIT	PART NO.	TITLE:	Customer NO.
				X.X	±0.40							
A1	2025.11.17	Part Number Change	OHJ	X.XX	±0.25	OHJ	2025.11.17	UNIT	mm	3601-2HXXXB01	1.27mm BTB Cable Assembly	
AO	2021.11.25	NEW	Andrey.yang	X.XXX	±0.15	CHECK	DATE	SIZE	A4		Female Header Series Conn.	
				Angle	± 3'	APPROVE	DATE	SHEET	1/3			
				DIM	TOL			PROJ.				

**WCON**

Http: www.wcon.com

WCON-Dongguan Tel: +86 769 85358920  
 WCON-Kunshan Tel: +86 512 57468408  
 Fax: +86 769 85358915  
 Fax: +86 512 57468468  
 E-mail: sales@wcon.com  
 E-mail: salesks@wcon.com

# HSF

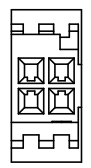

Notch+No Bump Locking  
2\*2 -2\*50P

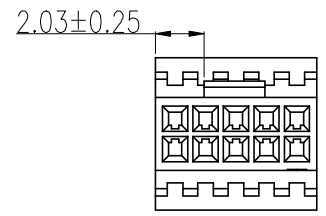

No Notch+Bump Locking  $\triangle$   
2\*5,2\*7,2\*8

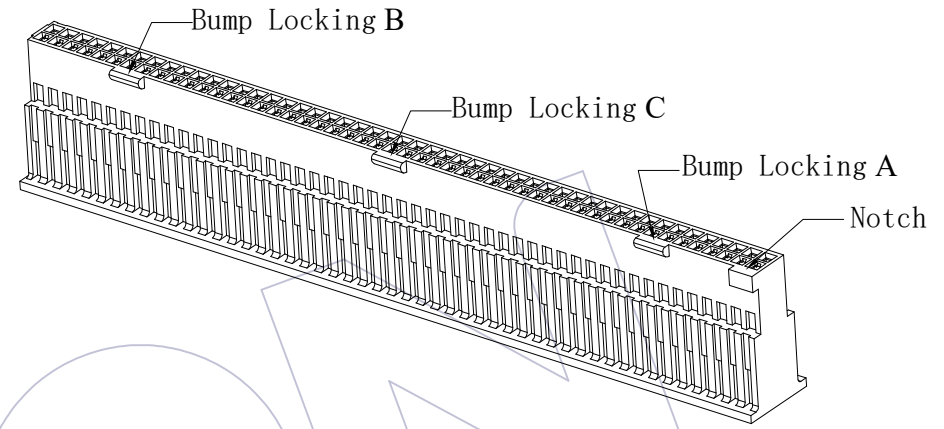

Notch+Bump Locking

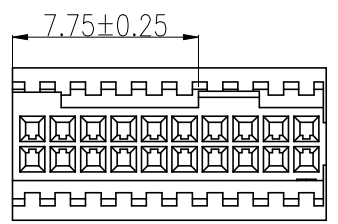

2\*10 -2\*20P

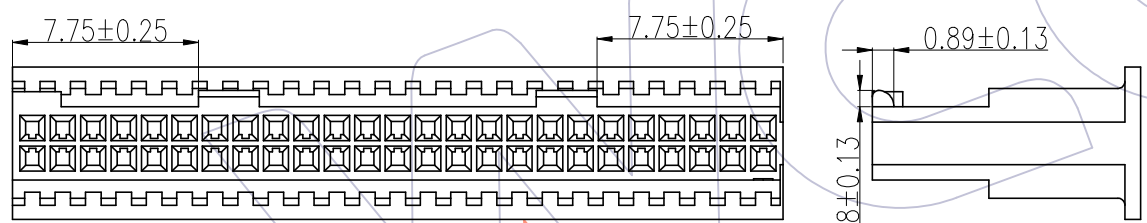

2\*25-2\*30P

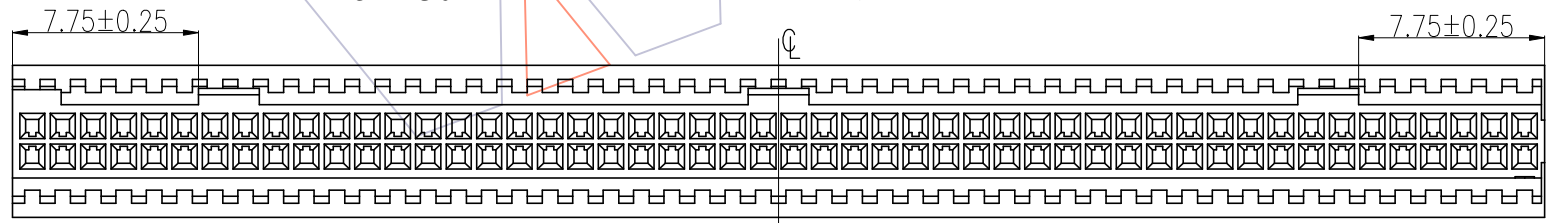

2\*35-2\*50P

Table 2:

Code	Pin No.	Notch	Bump Locking A	Bump Locking B	Bump Locking C
B	10,14,16	NO	YES	NO	NO
	20-40	YES	YES	NO	NO
A	50-60	YES	YES	YES	NO
	70-100	YES	YES	YES	YES
Blank	ALL PIN	YES	NO	NO	NO

REV	DATE	MODIFICATION DESCRIPTION	CHANGE	OPERATION		DRAW	DATE	SCALE	FIT	PART NO.
				X.X	±0.40					
A1	2025.11.17	Part Number Change	OHJ	X.XX	±0.25	OHJ	2025.11.17	UNIT	mm	3601-2HXXB01 $\triangle$ TITLE: 1.27mm BTB Cable Assembly Female Header Series Conn. Customer NO.
AO	2021.11.25	NEW	Andrey.yang	X.XXX	±0.15	CHECK	DATE	SIZE	A4	
				Angle	± 3'	APPROVE	DATE	SHEET	2/3	
				DIM	TOL			PROJ.		

Http: [www.wcon.com](http://www.wcon.com)

WCON-Dongguan Tel: +86 769 85358920 Fax: +86 769 85358915 E-mail: <a href="mailto:sales@wcon.com">sales@wcon.com</a>	WCON-Kunshan Tel: +86 512 57468408 Fax: +86 512 57468468 E-mail: <a href="mailto:salesks@wcon.com">salesks@wcon.com</a>
---	--

# HSF

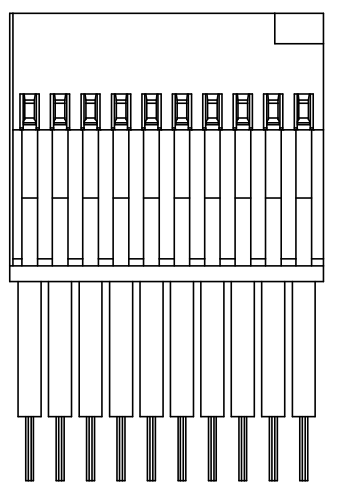

Assembly Hint View

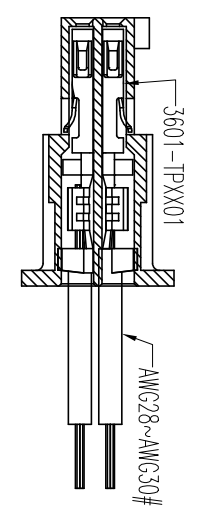

3601-1PXX01  
AMC28~AMC30#

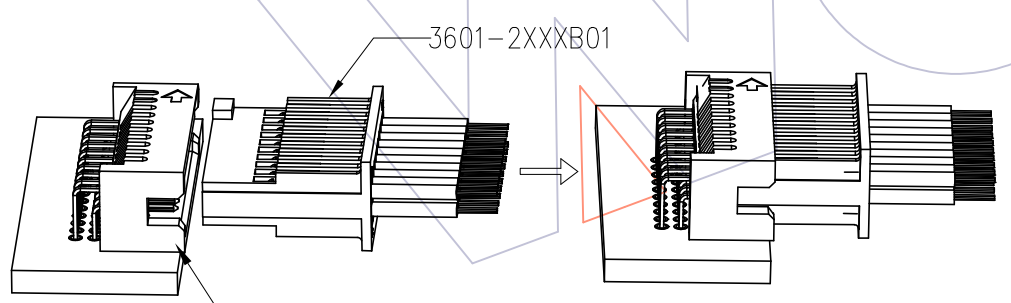

3601-2XXXB01

90° DIP MALE

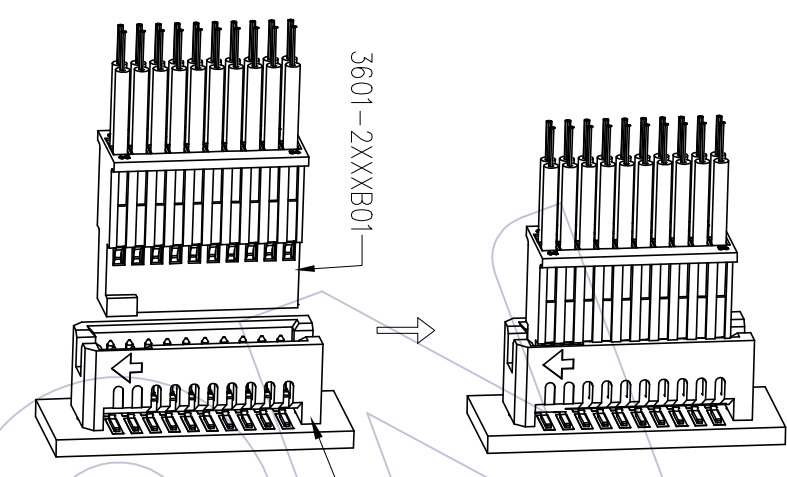

3601-2XXXB01

180° SMT MALE

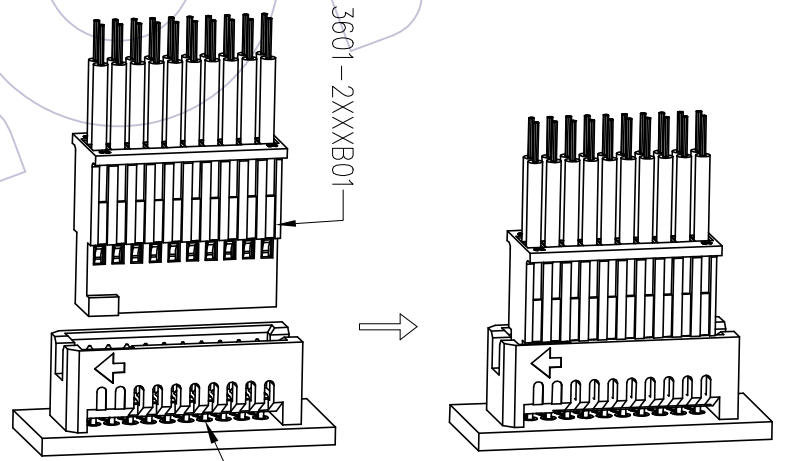

3601-2XXXB01

180° DIP MALE

			OPERATION		DRAW		DATE		SCALE		FIT		PART NO.	
			x.x ±0.40		OHJ		2025.11.17		UNIT		mm		3601-2HXXXB01	
A1 2025.11.17			x.xx ±0.25		CHECK		DATE		SIZE		A4		TITLE:	
AO 2021.11.25			x.xxx ±0.15		APPROVE		DATE		SHEET		3/3		1.27mm BTB Cable Assembly	
REV DATE			Angle ± 3'						PROJ.		Customer NO.		Female Header Series Conn.	
MODIFICATION DESCRIPTION			DIM TOL										WCON	
CHANGE													Http: www.wcon.com	
													WCON-Dongguan	
													WCON-Kunshan	
													Tel: +86 769 85358920	
													Tel: +86 512 57468408	
													Fax: +86 769 85358915	
													Fax: +86 512 57468468	
													E-mail: sales@wcon.com	
													E-mail: salesks@wcon.com	