

HSF

NOTES:

- Rated Current: 1.5AMP.(20°C, 1*2P-1*15P)
1.0AMP.(20°C, 1*16P-1*50P) $\triangle A2$
- Contact Resistance: 20mΩ Max.
- Withstand Voltage: 500V AC/DC
- Insulation Resistance: 1000MΩ Min.
- Operation Temperature: -40°C to +125°C (Gold Plating)
-40°C to +105°C (Tin Plating) $\triangle A2$
- Contact Material: Copper Alloy
- Contact Plating: Au or Sn Over 30u" Min Ni $\triangle A2$
- Insulator Material: PA9T+G.F UL94V-0 BK $\triangle A2$

Ordering Information

1317-2 1 XX XX R XXX C A XX $\triangle A2$

- Plastic Layer
- Plastic Row
- No. of Pins Per Row: 02-50
- Contact Plating
- G0=Gold Flash
- G3=10u"Au, BG3=8u"PdNi+2u"Au
- G4=15u"Au, BG4=13u"PdNi+2u"Au
- G5=30u"Au, BG5=28u"PdNi+2u"Au
- S0=Gold Flash/Tin
- S3=10u"Au/Sn, P3=8u"PdNi+2u"Au/Sn
- S4=15u"Au/Sn, P4=13u"PdNi+2u"Au/Sn
- S5=30u"Au/Sn, P5=28u"PdNi+2u"Au/Sn
- SN=Bright Tin
- SM=Matte Tin
- Series No. 01-99
- Packing A=Tray
- Insulator Material C=PA9T(Standard)
- Pin Length L(See Table)
- Type: R=R/A

Item	Pin Length	A	C	D	E	B	Mating
Standard	12.3	3.00	5.0	1.0	6.23	2.0	2321/2320T
	13.3					3.0	2334/2344/2346
	13.8					3.5	2357
	14.8					4.5	2345/2385
Standard	11.3	2.0 (THR)	5.0	1.0	6.23	2.0	2321/2320T
	12.3					3.0	2334/2344/2346
	12.8					3.5	2357
	13.8					4.5	2345/2385
Alternate							

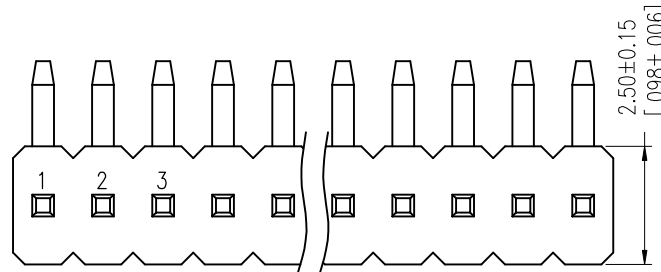

Recommended P.C.B Layout (Top Side)
(PCB BOARD TOLERANCE±0.05)
(PCB Thickness:T=1.60m)

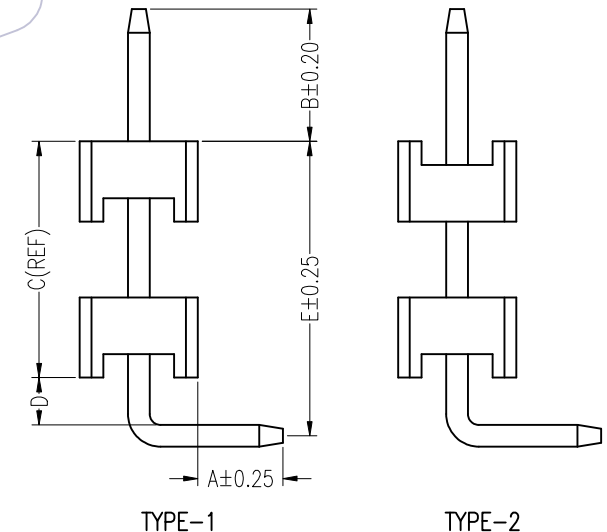
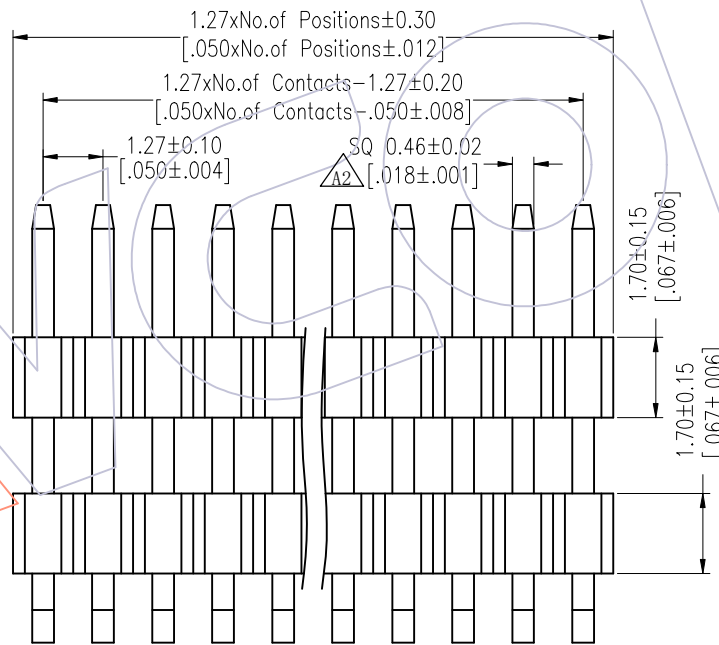
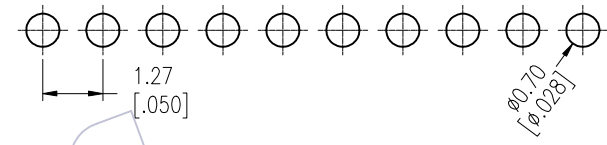

REV	DATE	MODIFICATION DESCRIPTION	CHANGE	OPERATION	DRAW	DATE	SCALE	Fit	PART NO.
A2	2025/08/14	Standardization Drawing	CP	x.X ±0.40	CP	2025/08/14	UNIT	mm [inch]	1317-21XXXXRXXXCXXX $\triangle A2$
A1	2018/01/17	MODIFY PART NO.	William Chen	x.xx ±0.25	CHECK	2025/08/14	SIZE	A4	TITLE: 1.27 Pin Header, SINGLE ROW, R/A, DOUBLE PLASTIC, CONCAVE BENDING, H=1.7
AO	2012/03/16	NEW	William Chen	x.xxx ±0.15	TANG	2025/08/14	SHEET	1/2	Customer NO.
				Angle ± 3'	APPROVE	2025/08/14	PROJ.		
				DIM TOL	Steven Zhao				

WCON
Http: www.wcon.com

WCON-Dongguan
Tel: +86 769 85358920
Fax: +86 769 85358915
E-mail: sales@wcon.com

WCON-Kunshan
Tel: +86 512 57468408
Fax: +86 512 57468468
E-mail: salesks@wcon.com

HSF

Packing:

Packaging Quantity Refers To The Following Table

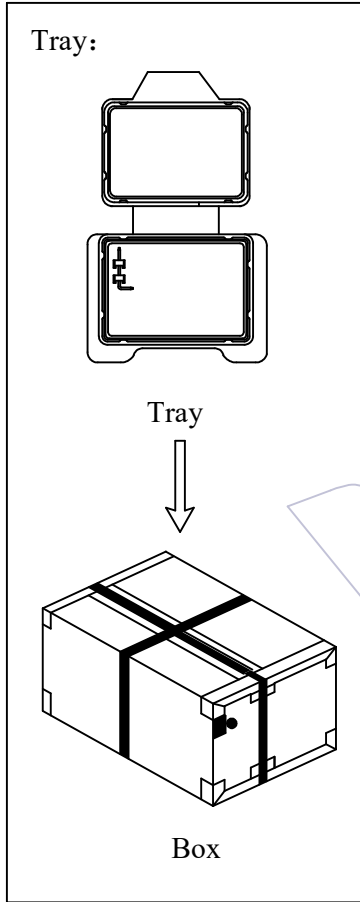

PINS	Q' ty/Tray (11≤L≤13)	Q' ty/Box	PINS	Q' ty/Tray (11≤L≤13)	Q' ty/Box	PINS	Q' ty/Tray (13<L≤14.5)	Q' ty/Box	PINS	Q' ty/Tray (13<L≤14.5)	Q' ty/Box
1	900	43,200	26	40	1,920	1	800	38,400	26	30	1,440
2	500	24,000	27	40	1,920	2	400	19,200	27	30	1,440
3	300	14,400	28	40	1,920	3	300	14,400	28	30	1,440
4	200	9,600	29	30	1,440	4	200	9,600	29	30	1,440
5	200	9,600	30	30	1,440	5	150	7,200	30	30	1,440
6	150	7,200	31	30	1,440	6	150	7,200	31	30	1,440
7	150	7,200	32	30	1,440	7	100	4,800	32	20	960
8	100	4,800	33	30	1,440	8	100	4,800	33	20	960
9	100	4,800	34	30	1,440	9	100	4,800	34	20	960
10	100	4,800	35	30	1,440	10	80	3,840	35	20	960
11	80	3,840	36	30	1,440	11	80	3,840	36	20	960
12	80	3,840	37	20	960	12	60	2,880	37	20	960
13	80	3,840	38	20	960	13	60	2,880	38	20	960
14	70	3,360	39	20	960	14	60	2,880	39	20	960
15	60	2,880	40	20	960	15	50	2,400	40	20	960
16	60	2,880	41	20	960	16	50	2,400	41	20	960
17	60	2,880	42	20	960	17	50	2,400	42	20	960
18	50	2,400	43	20	960	18	50	2,400	43	20	960
19	50	2,400	44	20	960	19	40	1,920	44	20	960
20	50	2,400	45	20	960	20	40	1,920	45	20	960
21	50	2,400	46	20	960	21	40	1,920	46	15	720
22	40	1,920	47	20	960	22	40	1,920	47	15	720
23	40	1,920	48	20	960	23	40	1,920	48	15	720
24	40	1,920	49	20	960	24	30	1,440	49	15	720
25	40	1,920	50	20	960	25	30	1,440	50	15	720

REV	DATE	MODIFICATION DESCRIPTION	CHANGE	OPERATION	DRAW	DATE	SCALE	Fit	PART NO.
A2	2025/08/14	Standardization Drawing	CP	x.X ±0.40	CP	2025/08/14	UNIT	mm [inch]	1317-21XXXXRXXXCXXX
A1	2018/01/17	MODIFY PART NO.	William Chen	x.xx ±0.25	CHECK	DATE	SIZE	A4	TITLE:
AO	2012/03/16	NEW	William Chen	x.xxx ±0.15	TANG	2025/08/14	SHEET	2/2	1.27 Pin Header, SINGLE ROW, R/A, DOUBLE PLASTIC, CONCAVE BENDING, H=1.7
				Angle ± 3'	APPROVE	DATE	PROJ.		Customer NO.
				DIM TOL	Steven Zhao	2025/08/14			



Http: www.wcon.com

WCON-Dongguan Tel: +86 769 85358920 Fax: +86 769 85358915 E-mail: sales@wcon.com	WCON-Kunshan Tel: +86 512 57468408 Fax: +86 512 57468468 E-mail: salesks@wcon.com
---	--